

NOTES: UNLESS OTHERWISE SPECIFIED

1. SEE DRAWING NO. CB-00285 AND PROCEDURE P-1000 FOR ASSEMBLY AND TEST INSTRUCTION. PROCEDURES AND ASSEMBLY DRAWINGS ARE FOR INTERNAL USE ONLY.
2. ALL TESTING IS PERFORMED IAW BATTERY COUNCIL INTERNATIONAL STANDARDS.
3. ALL DIMENSIONS ARE INCH [MM].

REVISIONS			
REV	DESCRIPTION	DATE	APPROVED
A	REMOVED SIDE HOLD-DOWNS	6/10/03	JBT
B	REDESIGNED COVER	5/29/18	PH

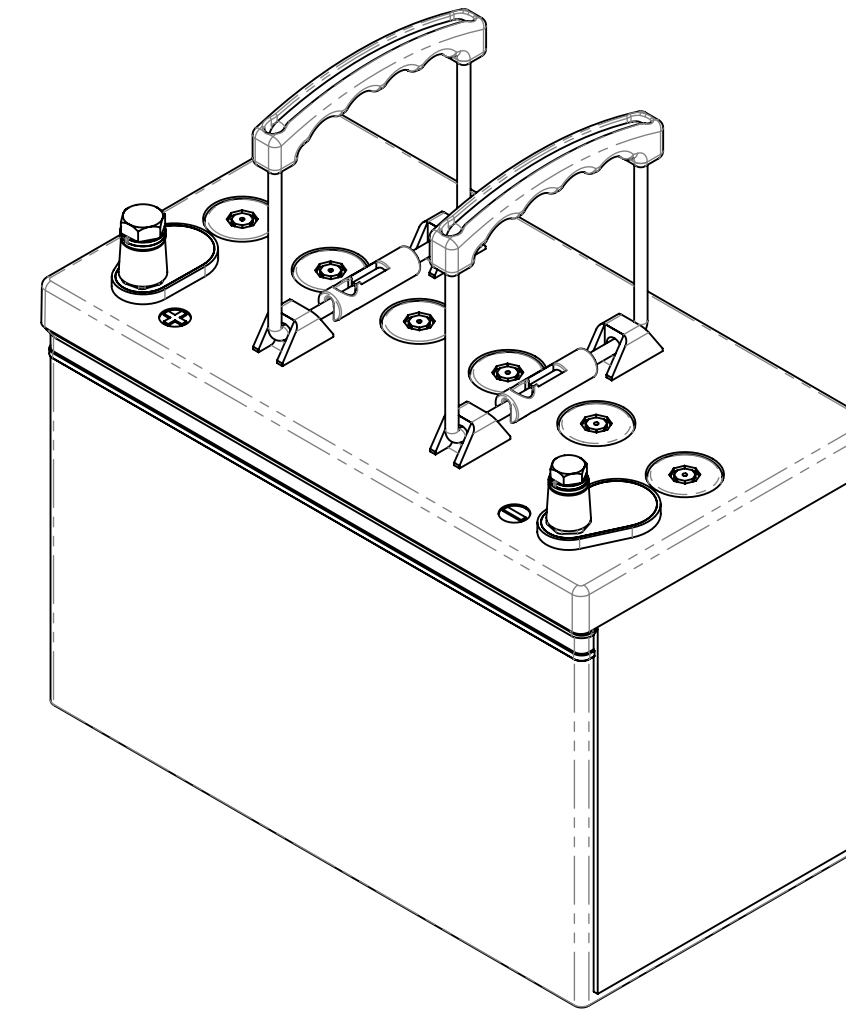
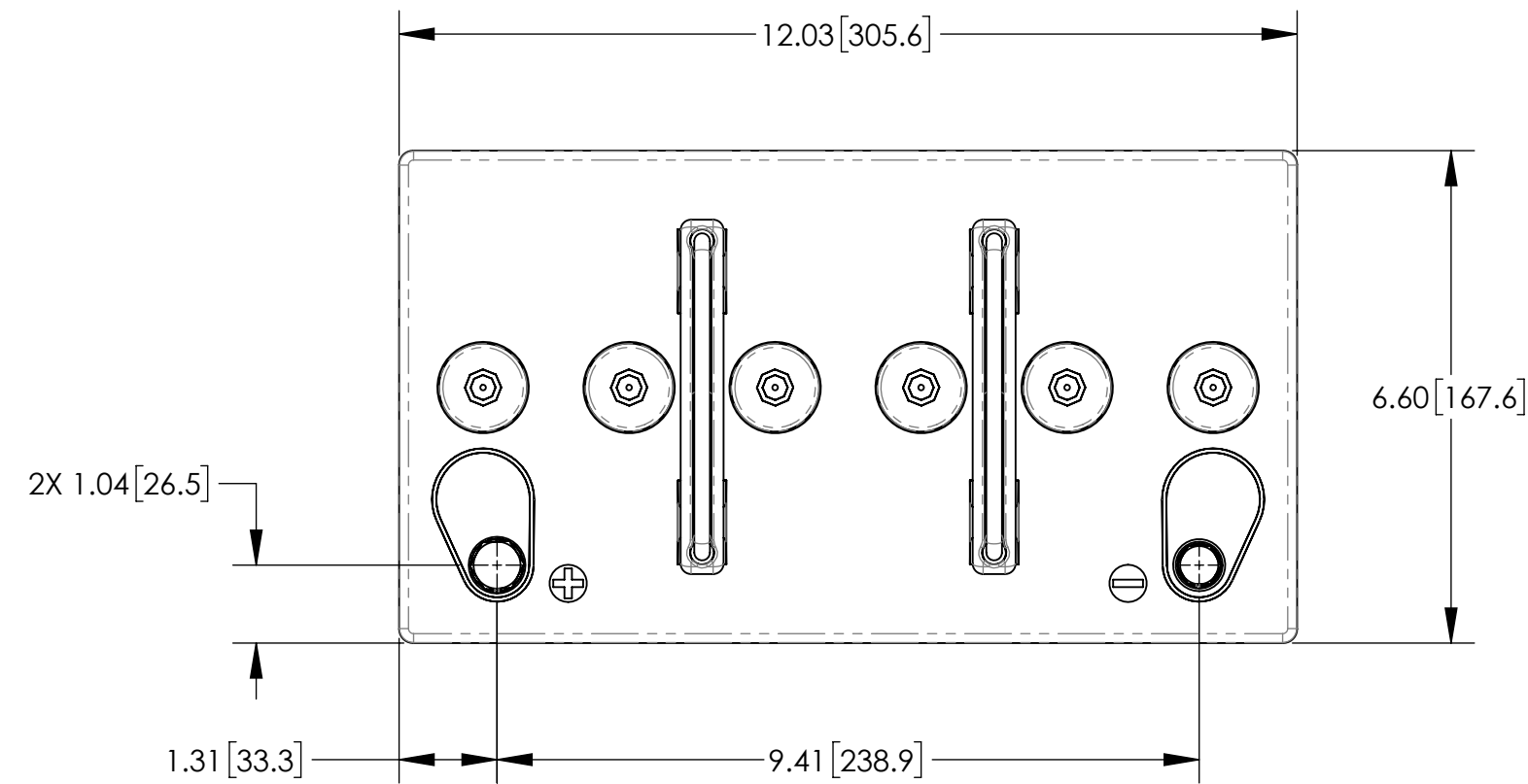

ISOMETRIC VIEW

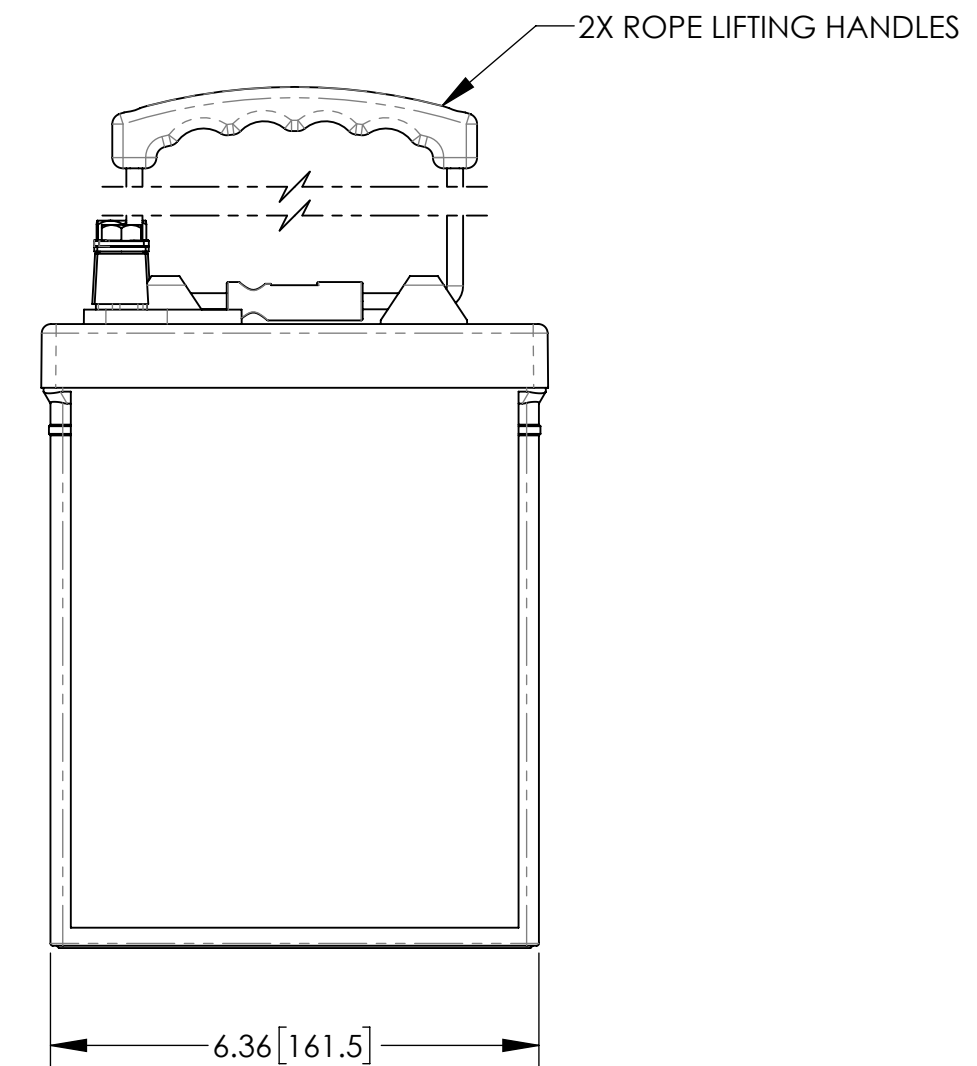
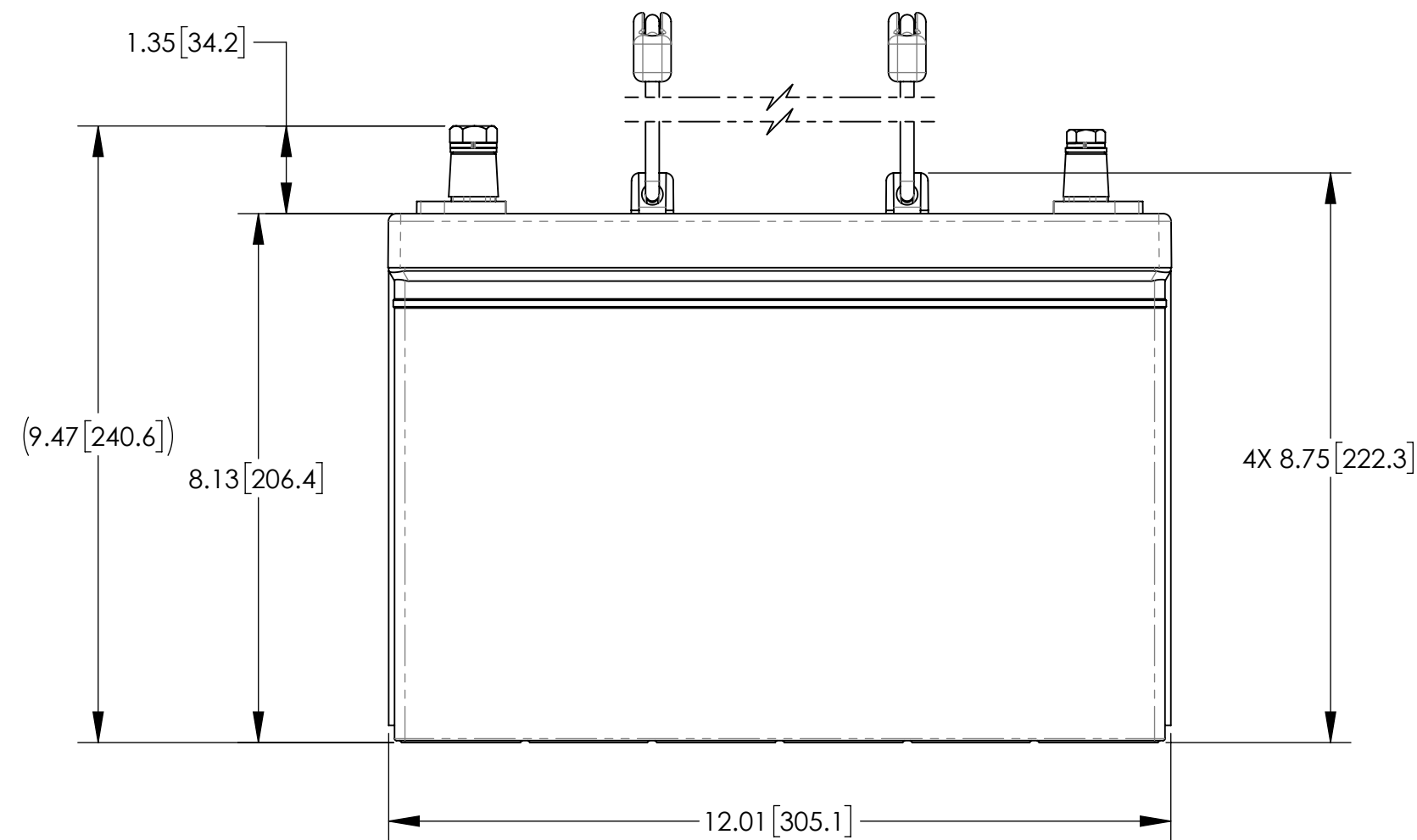

ENVELOPE DRAWING

CAPACITY RATINGS	
PART NUMBER	GPL-2700T
NOMINAL WEIGHT	63 LBS [28.6 KG]
AMPERE HOUR CAPACITY @ 20 HOUR 1.75 VOLTS/CELL @ 77°F (25°C)	95 AH
MINUTES OF DISCHARGE @ 25 AMPS 1.75 VOLTS/CELL @ 77°F (25°C)	206 MIN
COLD CRANKING AMPS @ 68°F	1020
COLD CRANKING AMPS @ 32°F	900
COLD CRANKING AMPS @ 0°F	745

UNLESS OTHERWISE SPECIFIED DIMENSIONS ARE IN INCHES TOLERANCES ARE:			CONTRACT NO.		CONCORDE BATTERY CORPORATION 2009 SAN BERNARDINO RD, W. COVINA, CA 91790		
FRACTIONS	DECIMALS	ANGLES	APPROVALS	DATE	TITLE		
±1/32	.XX ± .06 .XXX ± .030	±1°	DRAWN S. FRAZIER	05/07/02	BATTERY, 12 VOLT, GPL-2700T		
TREATMENT	NONE		CHECKED HRF	05/14/02	SIZE	CAGE CODE	DWG NO.
FINISH	NONE		APPROVED JBT	05/17/02	C	63017	GPL-2700T
SIMILAR TO	CALC WT		ISSUED JG	5/30/18	SCALE	1:2.5	SHEET 1 OF 1
							REV B